

Clarke®

weld



ARC ACTIVATED HEADSHIELD

MODEL NO: PG4

PART NO: 6000716

OPERATION & MAINTENANCE INSTRUCTIONS



ORIGINAL INSTRUCTIONS

GC0518 iss 2

INTRODUCTION

Thank you for purchasing this CLARKE Headshield.

Before attempting to use this product, please read this manual thoroughly and follow the instructions carefully. In doing so you will ensure the safety of yourself and that of others around you, and you can look forward to your purchase giving you long and satisfactory service.

GUARANTEE

This product is guaranteed against faulty manufacture for a period of 12 months from the date of purchase. Please keep your receipt which will be required as proof of purchase.

This guarantee is invalid if the product is found to have been abused or tampered with in any way, or not used for the purpose for which it was intended.

Faulty goods should be returned to their place of purchase, no product can be returned to us without prior permission.

This guarantee does not effect your statutory rights.

TECHNICAL DATA

Viewing field (W x H)	98 X 43 mm
Shade available in Light State	DIN 4
Shade available in Dark State	DIN 9-13 Outside Adjustment
UV/IR protection	Max shade DIN16 at all times
Operating temperature range	-5°C to +55°C
Weight	0.54 kg
Switching time from light to dark	1/30,000 second or 0.033ms
Delay time from dark to light	0.1 - 1.0 second
Light Filter power control	Automatic
Power supply	Solar Cells / Lithium Battery CR2450
Construction material	Polyamide (flame retardant)

SAFETY PRECAUTIONS

This headshield is not suitable for laser welding, laser cutting or overhead welding applications or for oxy-acetylene.

- The protective plate in this headshield is breakable and will not protect against impact hazards. Never use the headshield without the protective cover plate installed.
- This headshield is designed for use in grinding, arc welding or cutting applications such as MIG/MAG, TIG, MMA, Plasma Arc and Carbon Arc.
- Use this headshield for face and eye protection against harmful rays, sparks and spatter from welding and cutting.
- Never place this product on a hot surface.
- Stop using the headshield if the filter fails to change from light to dark. Contact your Clarke dealer.
- Do not make any modifications to this product. Protection can be seriously impaired if modifications are made.
- When necessary, use identical replacement parts. This will ensure that the safety of the product is maintained.
- Do not use without the protective plate installed. Do not use if any part of the headshield is cracked or broken.
- Do not use this headshield for welding outside the range of DIN 9-13. Harm to the eyes and impaired eyesight may result. Always select the correct setting before use.

INVENTORY

1 x Arc-activated solar/lithium powered welding headshield

2 x Spare outside lens covers 124 x 99 mm

1 x Spare inside lens cover 108 x 59 mm

PREPARATION & USE

ADJUSTING THE HEADBAND TO FIT

1. The headband should be adjusted both in diameter and height to fit the wearer's head. To do this, turn the adjustment knob on the back of the headband either left or right to expand or contract the headband.
2. The top headband can be adjusted by bending the strap and positioning the peg in the appropriate hole.
3. The working position of the headshield and its raised position can be pre-set.
4. Loosen the adjusting nuts until you can lift the adjusting tab and position it against the backing plate to set the headband range of movement. Tighten the adjusting nut when satisfied.
5. You can remove the headband completely from the headshield by squeezing the side clips together and sliding it away from the adjusting knob assembly.

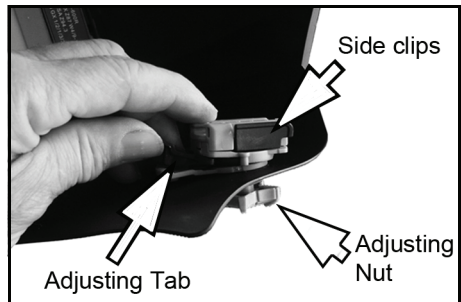
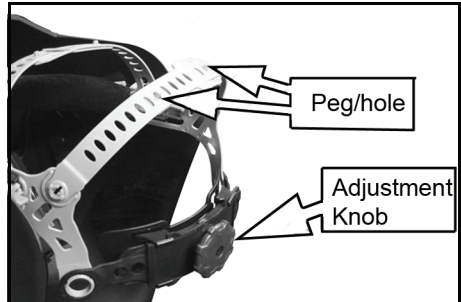

PREPARATION AND TESTING

1. Remove the protective film from the outer lens cover.
2. Unfasten the top and bottom retaining clips and lift the filter cartridge away while remaining connected to the control devices by the cable at each side.



3. Remove the outer lens cover from the headshield and peel away the protective film.
4. Clip the outer lens cover gently back into position.
5. Clip the filter cartridge back into position.

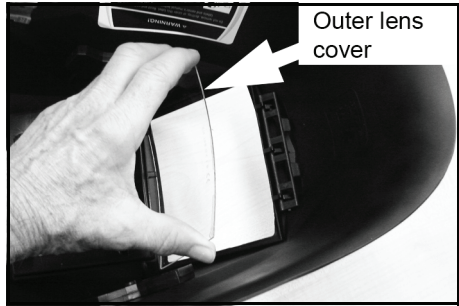

6. Lift and slide the inside lens cover (on the operators side of the filter cartridge) free from the filter cartridge and peel away the protective film. Re-fit the inside lens cover.
7. When refitting the cartridge, carefully seat it in position and fold back the retaining clips to secure.

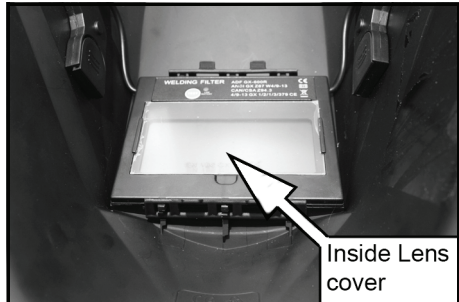

8. Test to see that the Auto Darkening Filter (ADF) is working, set the shade to any setting and press the **TEST** button inside the headshield. The display should change from light to dark and then back to light when the button is released. Confirm that the LOW BATTERY light does not light up.

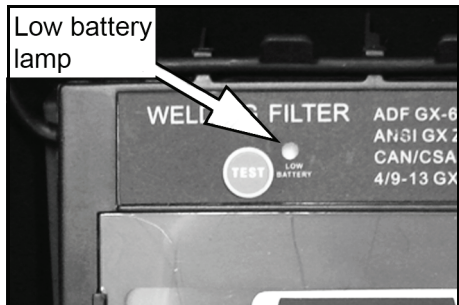

9. You can also test the filter by presenting any light source of greater than 400 lumens to the light sensor. Check that the display becomes dark and automatically returns to a light state when the light source is removed.
10. The lens will be set to Light DIN 4 state & you will be able to see the workpiece. The lens will automatically darken when an arc is struck.
 - If using at very low temperatures, the reaction time of the filter may slow down but will still afford full protection.
11. Check also that the outer screen and lens are clean and clear at all times.
12. Change the shade setting as required using the shade adjustment knob as described on page 5 and referring to the table on page 7.

SELECTING WELD OR GRIND SETTING

The headshield has a 'GRIND' setting, on the selector knob. When set to 'GRIND' the auto darkening function is disabled. The headshield then provides eye and face protection for sparks and airborne particles created during grinding operations.

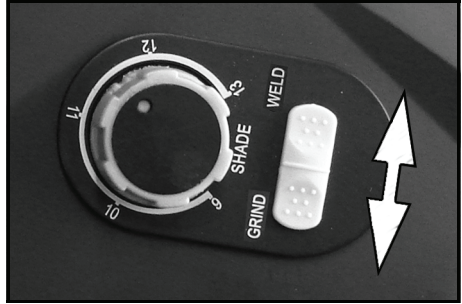

WARNING: IT IS ESSENTIAL THAT AFTER USING THE HEADSHIELD IN GRINDING MODE, IT SHOULD BE RETURNED TO THE WELD SETTING BEFORE WELDING. FAILURE TO DO THIS COULD LEAD TO EYE INJURY. MAKE A HABIT OF RETURNING THE SWITCH TO THE WELD SETTING.

SELECTING THE SHADE SETTING



WARNING: DO NOT USE FOR WELDING OUTSIDE THE RANGE OF DIN 9-13. INJURY TO THE EYES & LOSS OF EYESIGHT MAY BE CAUSED. MAKE SURE THAT WELDING MODE IS SELECTED BEFORE STRIKING AN ARC.

On striking an arc, the light created will activate the solar cell and the window will automatically darken to a preset level. The lithium batteries will provide the necessary energy to operate the headshield when there is no arc light.

You can adjust this shade level using the shade adjustment knob on the side of the headshield, corresponding to the type of welding process.

- There are five levels available; 9, 10, 11, 12 and 13. Check the table on page 7 to determine which you should select.
1. Set the helmet to WELD mode using the switch on the left side of the headshield.
 2. Turn the shade selector to the required setting.
 - During the welding operation the lens will automatically darken to the pre-set shade. On removal of the arc, the lens will return to the light state.

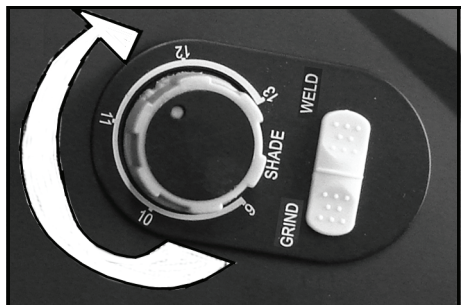

SHADE REFERENCE TABLE

Welding Process	Arc Current(Amperes)																								
	1,5	6	10	15	30	40	60	70	100	125	150	175	200	225	250	300	350	400	450	500	600				
SAW					8			9			10			11			12			13			14		
MAG					8			9			10			11			12			13			14		
TIG					8			9			10			11			12			13					
MIG(heavy)								9			10			11			12			13			14		
MIG(light)											10			11			12			13			14		
PAC											9			10			11			12			13		
PAW	4		5		6		7		8		9		10		11		12								
Note	★ SMAW-Covered electrodes										★ MIG(light)-MIG with light alloys														
	★ MAG-Metal arc Welding										★ PAC-Plasma jet cutting														
	★ TIG-Gas Tungsten Arc Welding										★ PAW-Microplasma arc welding														
	★ MIG(Heavy)-MIG with heavy metals																								

The shade number can be manually set from 9-13 using the adjusting knob on the left side of the headshield. Adjust the headshield to the correct shade shown in the table above.

Shade numbers according to BS 379, DIN 4647-1 and EN 169.

DELAY TIME ADJUSTMENT

The delay time is the time taken to switch back from fully dark to fully light and is selected using the switch on the right hand side of the headshield.

1. Set the minimum (0.1-0.25 sec) when spot welding, or doing short or seam welding work.
2. Set the delay to medium for most welding operations.
3. Set the maximum (0.85-1.0 sec) when doing high current welding.

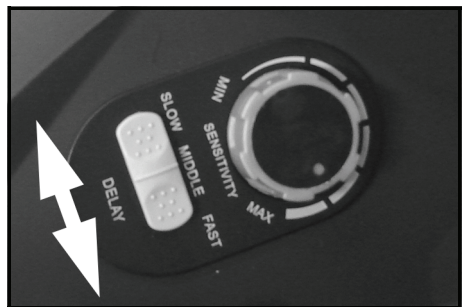

SENSITIVITY

The sensitivity can be adjusted using the knob on the right hand side of the headshield according to the type of welding and the background light. The mid range selection is suitable for most indoor and outdoor welding.

1. Select maximum for low current welding or when working in low light conditions, especially when welding argon arc with a low current.
2. Select minimum for high current welding or working in a brightly lit environment.

CARE & MAINTENANCE

Damaged components must be replaced immediately to avoid risk of eye and face injuries. Periodically inspect the filter cartridge and lens covers. Cracked, pitted or scratched lenses reduce vision and seriously reduce the level of protection and should be replaced with genuine, certified spare parts.

Never use sharp tools to remove foreign material sticking to the outer lens cover. This may cause damage which may cause incorrect function and invalidate the warranty.

The outer lens cover can be removed for replacement if damaged as described on page 4 and may need replacing regularly.

- Two replacement outer lens covers are supplied with the headshield.

The inner lens cover may also require cleaning. Lift and slide the inside lens cover (on the operators side of the filter cartridge) free from the filter cartridge as shown on page 5.

- A single replacement is supplied with this headshield.

Clean the filter surface, sensors and solar cells regularly by wiping with a household glass cleaner. Apply the cleaner with a clean cloth or paper towel. **DO NOT USE ALCOHOL TO CLEAN. DO NOT APPLY CLEANER DIRECTLY TO THE CARTRIDGE.**

Clean the headshield shell and sweat bands with detergent if necessary.

BATTERY REPLACEMENT

The batteries should last approximately 5000 hours of normal use. If the LOW BATTERY lamp comes on, (Low Volume Alarm), the battery should be replaced.

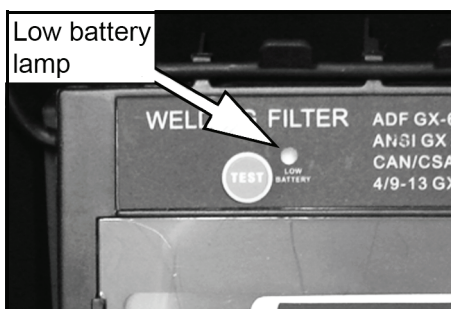

The batteries are located in the back of the welding and shade control housings and can be removed after pressing firmly on the cover plate and sliding it away. Use a small blade to lift the battery from its retaining clips.

- The headshield uses CR2450 Lithium batteries obtainable from most electrical retailers.

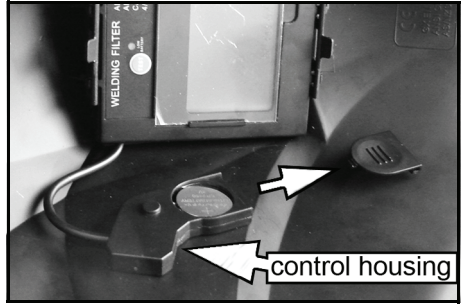

STORAGE

Store the headshield in its box or similar safe place.

ENVIRONMENTAL PROTECTION

If broken, do not dispose of this product with general household waste. This product contains valuable raw materials and should be disposed of appropriately at a recognised disposal facility.

Through purchase of this product, the customer is taking on the obligation to deal with the WEEE in accordance with the WEEE regulations in relation to the treatment, recycling & recovery and environmentally sound disposal of the WEEE.

This means that this product must not be disposed of with general household waste. It must be disposed of according to the laws governing Waste Electrical and Electronic Equipment (WEEE) at a recognised disposal facility.

COMPONENT PARTS

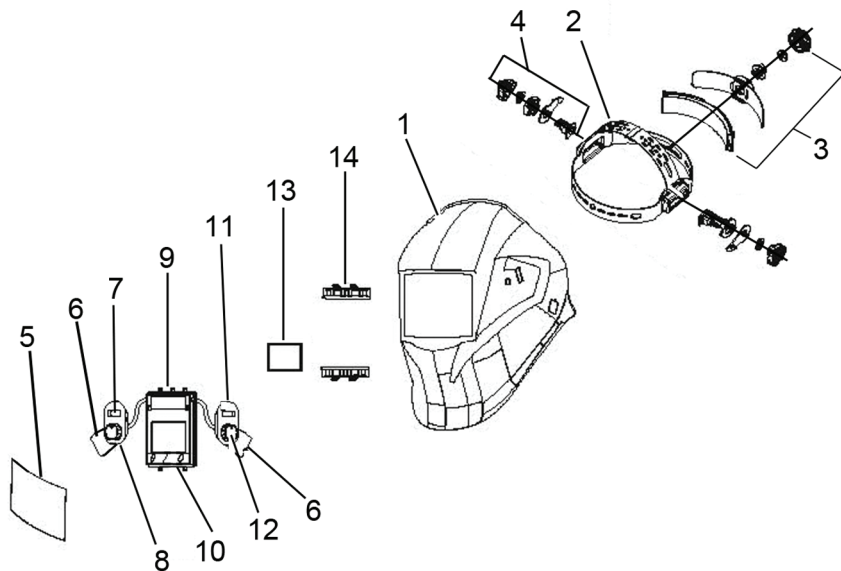

1	Headshield Shell
2	Adjustable Headband
3	Headband Adjustment parts
4	Angle/Distance Adjusting parts
5	Outside Lens Cover
6	Battery Compartment
7	Time Delay Switch

8	Sensitivity Control
9	Filter Cartridge
10	LCD
11	Welding/Grinding Switch
12	Variable Shade Control
13	Inside Lens Cover
14	Filter Cartridge Retaining Clip

DECLARATION OF CONFORMITY



Clarke[®]
INTERNATIONAL

Hemncill Street, Epping, Essex CM16 4LG

DECLARATION OF CONFORMITY

This is an important document and should be retained.

Product Description: Arc Activated Head Shield With Grinding Function
Model number(s): PG4
Serial / batch Number: N/A
Date of Issue: 08/09/2015
Certificate Number: C4957GX/R0, C4899GX/R1, C4898GX/R0, C4946GX/R0
Notified Body: NB 0196
DIN CERTCO GESELLSCHAFT FÜR KONFORMITÄTSBEWERTUNG MBH
Alboinstraße 56
12103 BERLIN
Germany

We hereby declare that this product(s) complies with the following directive(s):

89/686/EEC *Personal Protective Equipment Directive*
2011/65/EU *Restriction of Hazardous substances.*

The following standards have been applied to the product(s):

DIN EN 175:1997-08, DIN EN 166:2002-04, DIN EN 379:2009-07.

The technical documentation required to demonstrate that the product(s) meet(s) the requirement(s) of the aforementioned directive(s) has been compiled and is available for inspection by the relevant enforcement authorities.

The CE mark was first applied in: 2014

Signed:

.....
J.A. Clarke
Director

A SELECTION FROM THE VAST RANGE OF

Clarke®

QUALITY PRODUCTS

AIR COMPRESSORS

From DIY to industrial, Plus air tools, spray guns and accessories.

GENERATORS

Prime duty or emergency standby for business, home and leisure.

POWER WASHERS

Hot and cold, electric and engine driven - we have what you need

WELDERS

Mig, Arc, Tig and Spot. From DIY to auto/industrial.

METALWORKING

Drills, grinders and saws for DIY and professional use.

WOODWORKING

Saws, sanders, lathes, mortisers and dust extraction.

HYDRAULICS

Cranes, body repair kits, transmission jacks for all types of workshop use.

WATER PUMPS

Submersible, electric and engine driven for DIY, agriculture and industry.

POWERTOOLS

Angle grinders, cordless drill sets, saws and sanders.

STARTERS/CHARGERS

All sizes for car and commercial use.

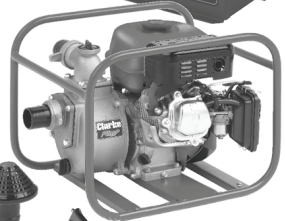

PARTS & SERVICE: 0208 988 7400
E-mail: Parts@clarkeinternational.com or Service@clarkeinternational.com

SALES: UK 01992 565333 or Export 00 44 (0)1992 565335

Clarke® INTERNATIONAL Hemnall Street, Epping, Essex CM16 4LG
www.clarkeinternational.com